



WETLAND

EQUIPMENT COMPANY

118 W Main St. Thibodaux, LA 70301

Phone: 985-447-0354

www.wetlandequipment.com

45-50 Metric Ton Amphibious Excavator

Model #: 45E

Amphibious Undercarriage Weight:

75,000 pounds (34,019 kg)

Excavator Weight:

65,000 pounds (29,483 kg)

Gross Weight:

140,000 pounds (63,502 kg)

Ground Pressure:

1.85 lbs. P.S.I. (0.13 kg/cm²)

Assembled Dimensions:

40' 0" (12.1 m) Long

23' 0" (7 m) Wide

7' 8" (2.3 m) High

14' 5" (4.4 m) High with excavator

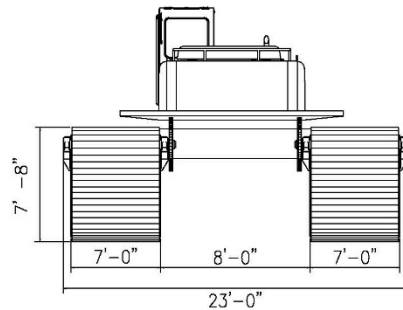
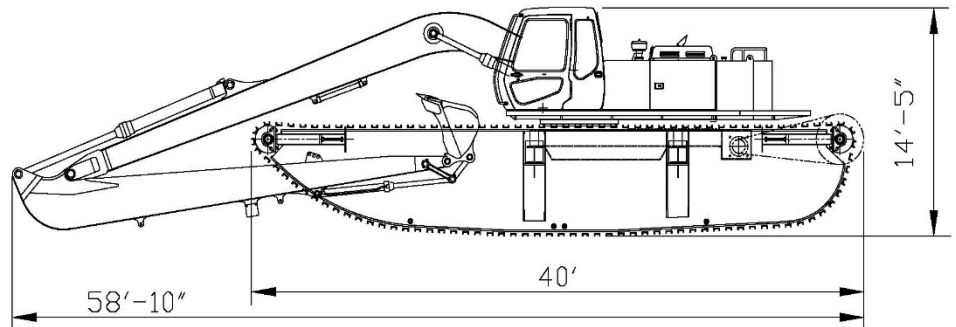

Pontoon construction: Multiple grades of steel are used in production of our pontoons. We design for strength, abrasion, and weight where needed. Some of the steel grades we use are (A36, A572, AR 400-550). Each pontoon has 8 compartments 3 bulkheads providing 4 independent watertight compartments. The pontoon bottoms are reinforced for rough terrain operation. Recessed chains and pads help keep side movement and jumping tracks to a minimum. Recessed channels also add structural strength and keep mud and debris to a minimum and away from the pontoons.

Drive System: Hydraulic travel motors, brakes and gearboxes (all watertight) provide the tracking power and are specifically designed by Wetland Equipment for operation in the most extreme conditions anywhere in the world. Pontoon tracks are driven independently of each other using conventional excavator controls. Final reduction is provided by chain and sprocket. Drive axles and sprockets use splined shafts and hubs. No Keyways are used.

Speed: up to 1.5 mph on hard dry surface & 0.5 mph in water (2.4 km/h dry land, 0.8 km/h water)

Grade: 100% (45°)

Drive Chain: Heavy Duty double crimped roller chain

45-50 Metric Ton Amphibious Excavator

Track Chain: Four strands of heavy-duty 5" (127 mm) pitch marsh buggy track chain per pontoon.

Track Cleats: Specially designed 4" (101.6 mm) marine grade 6061-T6 extruded aluminum alloy cleats with 2 guide pads per cleat

Bearings: pontoons have bearings on all four corners. No Bushings are used

Pontoon Track Chain Adjustment: Track chain adjustments adjust full life of chain without removal of track chain links or cleats. Minimum of 18 in (457mm) on front and rear of pontoon

Paint: Blasted SP10, Zinced, primed, Poly Color coat (customer color choice) Ply Clear top coat. Inside pontoon primed to prevent rust (Standard Pontoon color is Black)

Upgrade Options (Most Popular):

Cat Walk: Down both sides of the excavator and around the counterweight fuel tank constructed of Steel bar grating. All designed to mount to the excavator body and bolted in place for easy removal.

Hand Rails: Removable hand rails designed to be mounted to the catwalks

Counterweight/fuel tank: Factory counterweight to be deleted and replaced with a 350-gallon (1,324.75 liters) combination fuel tank/ counterweight. Tank duplicates pontoon color and paint process. Tank has its own shut-off and directional valves. Tank is attached to excavator, and transfer pumps not required.

Additional Features:

- * Wider Overall for stability in water and safety of operator
- * Bolt together Assembly (NEVER Touch hydraulics)
- * All Our pontoons are built with patented features to reduce down time and improve productivity to keep machine working longer.
- * These patents keep cost down for the equipment owner

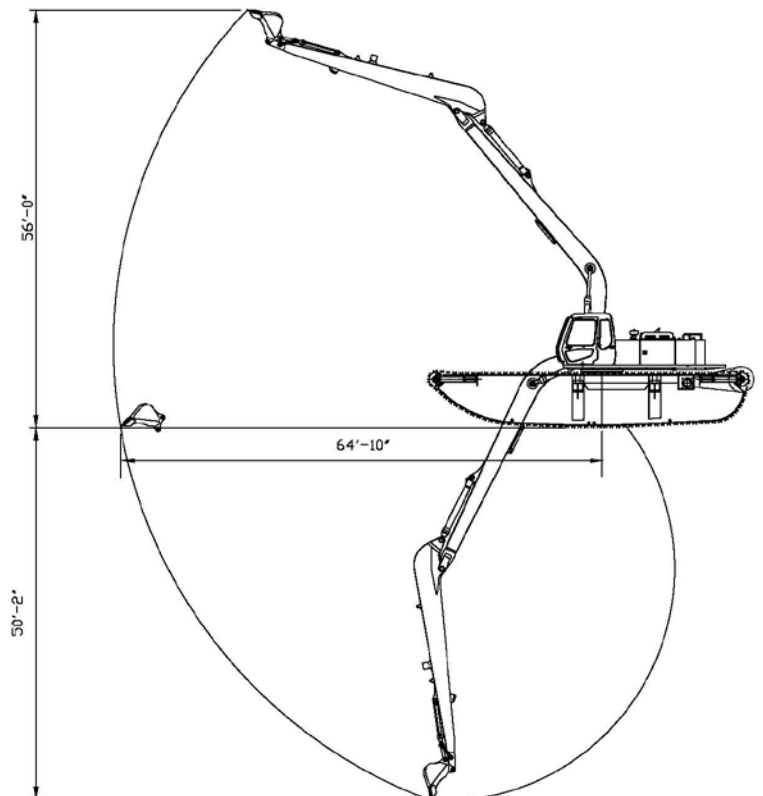

The above measurements and weights contained in this specification can change at any time without notice and are approximate pending upgraded options and brand of excavator